

SEZIONE A-A

USCITA ARIA REFRIGERATA  
TREADED AIR DISCHARGE  
ZULUFTAUSGANG  
SORTIE AIR GLACEE  
SALIDA AIRE ENFRIDA

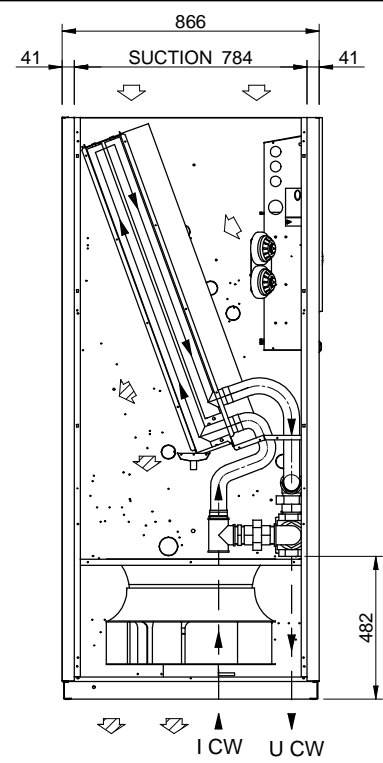

	I	GB	D	F	E
ICW 1-2 Ø 2" G	INGRESSO ACQUA REFRIGERATA	CHILLER WATER INLET	KALTWASSEREINGANG	ENTREE EAU GLACEE	ENTRADA AGUA ENFRIADA
UCW 1-2 Ø 2" G	USCITA ACQUA REFRIGERATA	CHILLER WATER OUTLET	KALTWASSERAUSSGANG	SORTIE EAU GLACEE	SALIDA AGUA ENFRIADA
IHW Ø 1 1/4" G	INGRESSO ACQUA CALDA	HOT WATER INLET	WARMWASSEREINGANG	ENTREE EAU CHAUDE	ENTRADA AGUA CALIENTE
UHW Ø 1 1/4" G	USCITA ACQUA CALDA	HOT WATER OUTLET	WARMWASSERAUSSGANG	SORTIE EAU CHAUDE	SALIDA AGUA CALIENTE
IP a-b	INGRESSO CAVO DI ALIMENTAZIONE	POWER SUPPLY CABLE INLET	SPEISEKABELINGANG	ENTREE CABLAGE D'ALIMENTATION	ENTREE CABLAGE ALIMENTATION
IS	INGRESSO USCITA SEGNALI	SIGNALS INLET / OUTLET	EINGANG / AUSGANG SIGNALE	ENTREE / SORTIE SIGNALES	ENTRADA / SALIDA SINALIZACIONES
IR	INGRESSO RETE	NETWORK INLET	NETZWERKEINGANG	ENTREE RESEAU	ENTRADA RED
F Ø 6	INGRESSO ACQUA UMIDIFICATORE	HUMIDIFIER WATER INLET	WASSEREINGANG BEFEUCHTER	ENTREE EAU HUMIDIFICATEUR	ENTRADA AGUA HUMECTADOR
C-D Ø 32	SCARICO ACQUA UMIDIFICATORE E/O CONDENSA	HUMIDIFIER / CONDENSATE DRAIN CONNECTION	KONDENSAT - BZB. BEFEUCHTERABFLUSS	DECHARGE EAU HUMIDIFICATEUR ET/OU CONDENSEUR	DESCARGA AGUA HUMECTADOR Y/O CONDENSADOR
AR Ø 100	INGRESSO ARIA DI RINNOVO	FRESH AIR INLET	FRISHLUFTEINGANG	ENTREE AIR NEUF	ENTRADA AIRE DE RENOVO

ICW2 - UCW2 = SOLO PER VERSIONE DUAL COIL  
ONLY VERSION DUAL COIL  
NUR VERSION DUAL COIL  
SEULEMENT VARIATION DUAL COIL  
SOLO VERSION DUAL COIL

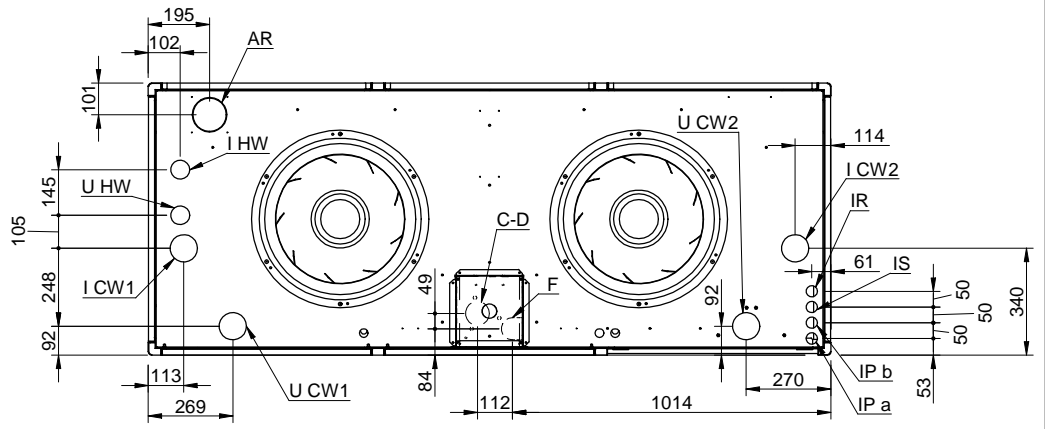

C Aggiunto uscita Dual Coil		M.Chiodetto	08/05/08		
REV.	Descrizione - Description	Disegnatore - Draftsman	Data - Date	Visto - Checked by	n' Com.
Materiale - Material		Trattamento - Treatment		Rif. Com.	
		Denominazione-Denomination <b>DISEGNO DI INSTALLAZIONE</b> <b>INSTALLATION DRAWING</b>		Series <b>TDC</b> Modello-Model <b>2000...2700</b>	
Scala-Scale	QUOTE SENZA INDICAZIONE DI TOLLERANZA <b>Grado di precisione medio</b> <b>UNI EN 22768-1(1996)</b>	Dis.-Draftsman <b>A.Miotto</b> Visto-Checked by	Foglio Sheet N. <b>1/1</b> Data-Date <b>04/10/2005</b>	Disegno-Drawing <b>DICI900X2A</b>	REV. <b>C</b>